

NINGBO TIANBO GANGLIAN ELECTRONICS CO CO., LTD

TRAF

SPECIFICATION

FILE NUMBER: T810S-G011A

DATE: 2004/06/25

■ CONTACT DATA

Contact Form	1A	
Contact Material	Silver Alloy	
Contact Ratings	Motor: inrush 80A 250VAC Break 20A 250VAC	Resistive:20A 250VAC
Max Switching Voltage	250VAC	
Max Switching Current	20A	
Max Switching Power	5000VA	
Contact Resistance	100m Ω Max	at 6VDC 1A
Life Expectancy Electrical	100, 000	Operations(at30Operations/minute)
Mechanical	10, 000, 000	Operations

■ GENERAL DATA

Insulation Resistance	100M Ω Min at 500VDC
Dielectric Strength Between Open Contacts	1500VAC(for one minute)
Between Contacts and coil	4500VAC(for one minute)
Operate Time	20ms
Release Time	10ms
Temperature Range	-25 $^{\circ}$ C to+55 $^{\circ}$ C
Shock Resistance	20G 11ms
Vibration Resistance	10-55Hz,1.5mm
Humidity	40-85%
Weight	Approx. 23g
Safety Standard	

■ COIL DATA

Nominal Voltage (VDC)	Coil Resistance at 20 $^{\circ}$ C \pm 10% (Ω)	Max Operate Voltage (VDC)	Min Release Voltage (VDC)	Max Applicable Voltage (VDC)
	0.9W			
5	27.8	3.75	0.5	6.5
6	40	4.5	0.6	7.8
12	160	9	1.2	15.6
24	640	18	2.4	31.2
48	2560	36	4.8	62.4

ORDERING CODE

TRAF—12VDC—S—H

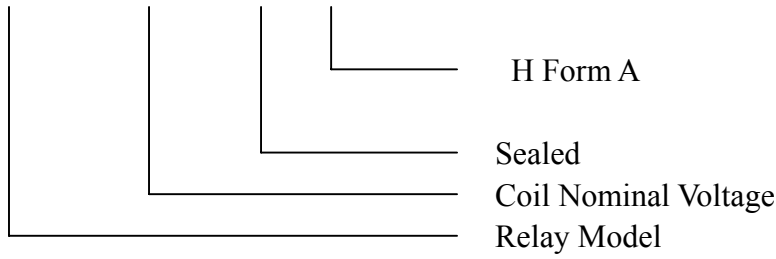

OVERALL AND MOUNTING DIMENSIONS

TRAF-H

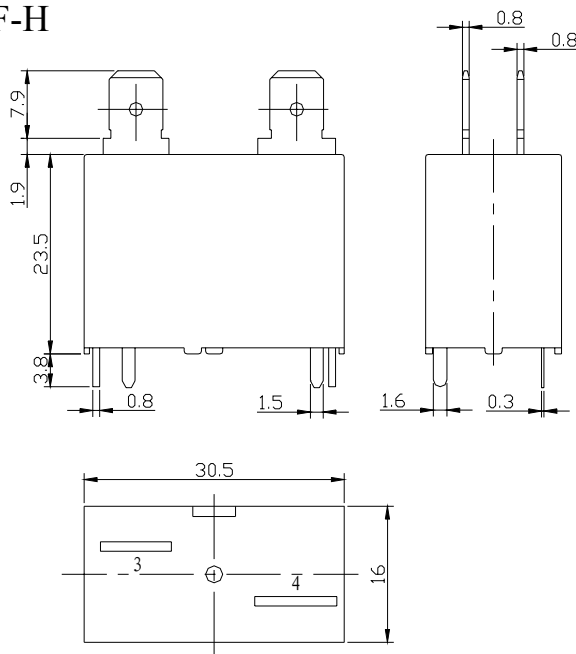

(Bottom terminals)

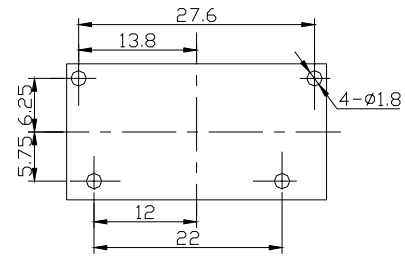

接线图 (Terminal arrangement)

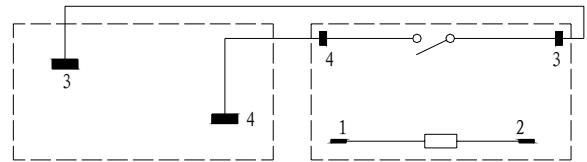

TRAF-H-P

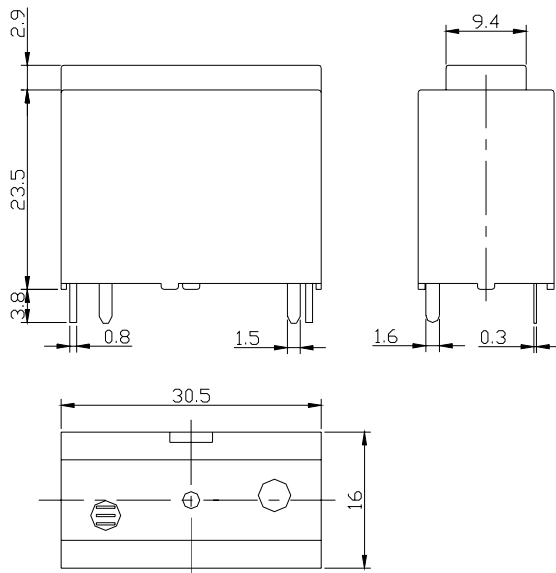

(Bottom terminals)

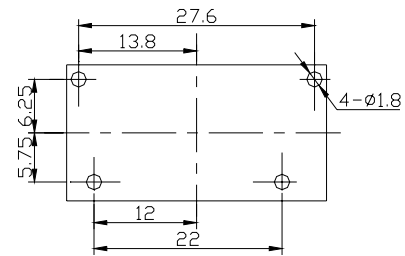

(Terminal arrangement)

